



## ADAPTER KIT TO POWER TAKE OFFS ZF

Ref.VK4007S

16-S-151 IT; 16-S-181 IT; 16-S-221 IT; 16-S-1621 TD IT; 16-S-1821 TO IT;  
16-S-1921 TD IT; 16-S-2221 TD/TO IT; 16-S-2321 TD IT; 16-S-2331 TD IT;  
16-S-2521 TO IT; 16-S-2721 TO IT; 16-S-2731 TO IT

### Main Dimensions

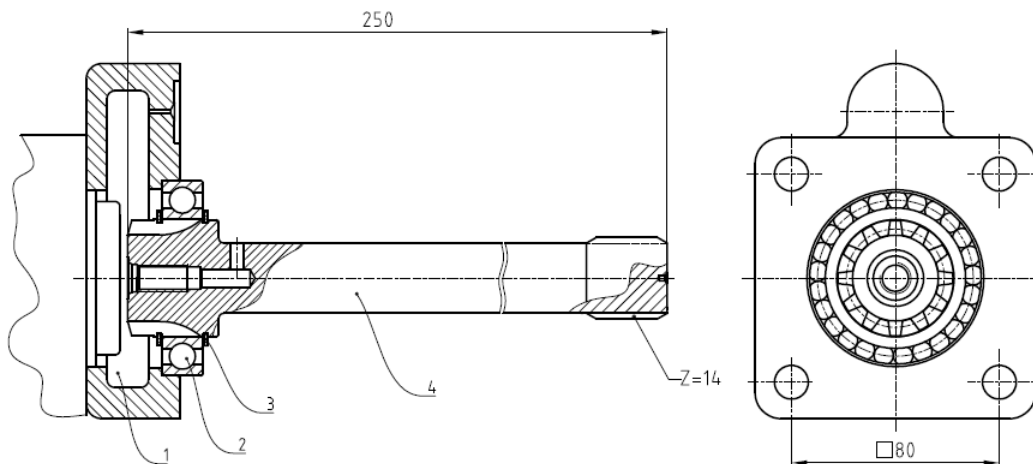

- 1 – Spacer
- 2 – Bearing
- 3 – Circlip
- 4 – Adapter shaft VK4007

(Dimensions in mm)

### Main Data

|  |   |
|--|---|
| <b>Continuous Torque (Nm)</b>  | <b>600</b>                                  |
| <b>Intermittent Torque (Nm)</b>  | <b>840</b>                                  |
| <b>Power (at 1000 r.p.m)</b>   | <b>85 H.P. / 64 Kw</b>                      |
| <b>Weight (Kg)</b>   | <b>2</b>                                    |
| <b>Engine-Kit adapter ratio</b>  |   |
| 16-S-151/221 /13.80 High:- 1 : 0.92 Normal:- 1 : 0.77                                  |   |
| /13.85 High:- 1 : 0.92 Normal:- 1 : 0.77   |   |
| /16.41 High:- 1 : 0.92 Normal:- 1 : 0.77   |   |
| /16.47 High:- 1 : 0.92 Normal:- 1 : 0.77   |   |
| /16.53 High:- 1 : 0.92 Normal:- 1 : 0.77   |   |
| 16-S-1621 TD IT; 16-S-1921 TD IT; 16-S-2221 TD IT; 16-S-2321 TD IT;<br>16-S-2331 TD IT | /16.41 High:- 1 : 0.91<br>Normal:- 1 : 0.77 |
| 16-S-1821 TO IT; 16-S-2221 TO IT; 16-S-2521 TO IT; 16-S-2721 TO IT;<br>16-S-2731 TO IT | /13.80 High:- 1 : 1.09<br>Normal:- 1 : 0.91 |

#### **KIT Studs:**

KIT VK4007S for PTO (ratio 1:1)

- 4 stud M12x155
- 4 nut M12
- 4 washer
- 1 jute ZF
- 1 jute IT

ABER is constantly engaged in improving its products and, therefore, reserves itself the right to modify without any further notice the characteristics shown. The gear boxes are in constant change; therefore, ABER is not to be held responsible for any damage resulting from wrong application or application of outdated material.



**ABER - Embragens e Comandos Hidráulicos - A. B. LDA**

Rua Francisco de Almeida, Nº 30 – Vila Nova da Telha – 4470 MAIA - Portugal

Telephone: +351.22.9438070 Fax: +351.22.9420823 e-mail: [aber@aber.pt](mailto:aber@aber.pt) <http://www.aber.pt>

1/1



## ADAPTER KIT TO POWER TAKE OFFS ZF

Ref.VK4007AM

16-S-151 IT; 16-S-181 IT; 16-S-221 IT; 16-S-1621 TD IT; 16-S-1821 TO IT;  
16-S-1921 TD IT; 16-S-2221 TD/TO IT; 16-S-2321 TD IT; 16-S-2331 TD IT;  
16-S-2521 TO IT; 16-S-2721 TO IT; 16-S-2731 TO IT

### Main Dimensions

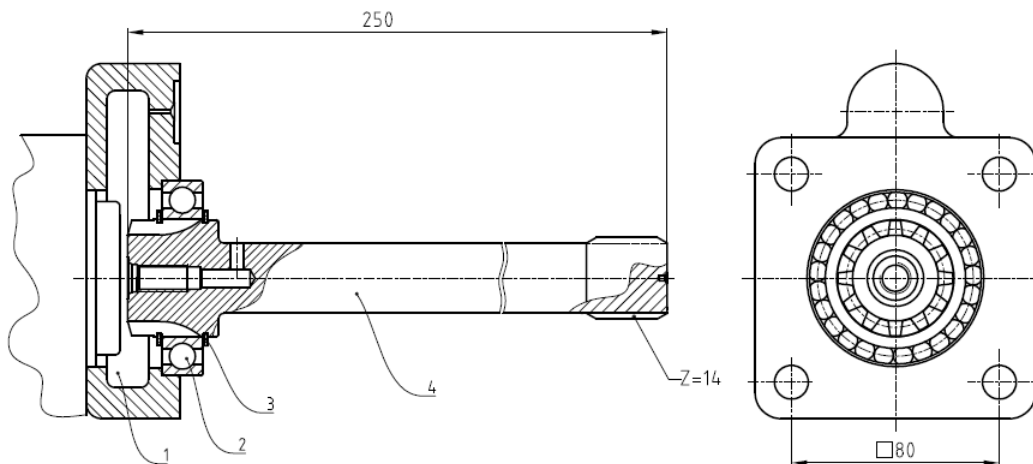

- 1 – Spacer
- 2 – Bearing
- 3 – Circlip
- 4 – Adapter shaft VK4007

(Dimensions in mm)

### Main Data

|                                 |                        |
|---------------------------------|------------------------|
| <b>Continuous Torque (Nm)</b>   | <b>600</b>             |
| <b>Intermittent Torque (Nm)</b> | <b>840</b>             |
| <b>Power (at 1000 r.p.m)</b>    | <b>85 H.P. / 64 Kw</b> |
| <b>Weight (Kg)</b>              | <b>2</b>               |

#### Engine-Kit adapter ratio

|  |                 |                                      |
|--|-----------------|--------------------------------------|
| 16-S-151/221 /13.80  | High:- 1 : 0.92 | Normal:- 1 : 0.77                    |
| /13.85   | High:- 1 : 0.92 | Normal:- 1 : 0.77                    |
| /16.41   | High:- 1 : 0.92 | Normal:- 1 : 0.77                    |
| /16.47   | High:- 1 : 0.92 | Normal:- 1 : 0.77                    |
| /16.53   | High:- 1 : 0.92 | Normal:- 1 : 0.77                    |
| 16-S-1621 TD IT; 16-S-1921 TD IT; 16-S-2221 TD IT; 16-S-2321 TD IT;<br>16-S-2331 TD IT | /16.41          | High:- 1 : 0.91<br>Normal:- 1 : 0.77 |
| 16-S-1821 TO IT; 16-S-2221 TO IT; 16-S-2521 TO IT; 16-S-2721 TO IT;<br>16-S-2731 TO IT | /13.80          | High:- 1 : 1.09<br>Normal:- 1 : 0.91 |

**Note:** For getting the correct ratio is necessary to multiply the above mentioned ratio by the internal ratio in all S6-90 releases.

**Example:** Gearbox 16-S-151 Adapter Kit + ZF S6-90 (Ref. TF4002AMP) Internal Ratio 1:1.32

Final ratio: High - 1 : 1.2144 (0.92 x 1.32 = 1.2144)  
Normal - 1 : 1.0164 (0.77 x 1.32 = 1.0164)

**KIT Studs:** KIT VK4007AM for PTO (ratio 1:1.32)

- 2 stud M12x135
- 2 stud M12x170
- 4 nut M12
- 4 washer
- 1 Jute ZF
- 1 Jute IT

ABER is constantly engaged in improving its products and, therefore, reserves itself the right to modify without any further notice the characteristics shown. The gear boxes are in constant change; therefore, ABER is not to be held responsible for any damage resulting from wrong application or application of outdated material.



**ABER - Embraigens e Comandos Hidráulicos - A. B. LDA**

Rua Francisco de Almeida, Nº 30 – Vila Nova da Telha – 4470 MAIA - Portugal

Telephone: +351.22.9438070 Fax: +351.22.9420823 e-mail: [aber@aber.pt](mailto:aber@aber.pt) <http://www.aber.pt>